

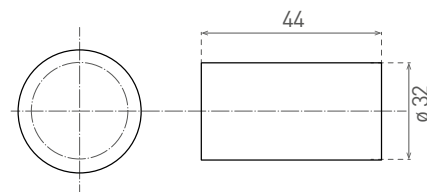

ELEKTROINSTALAČNÍ MATERIÁL

LH-E14

- KERAMICKÁ OBJÍMKA
- keramické tělo
- výborná tepelná odolnost



LH-E14	GX0S049	8592660103358	48	1/40/400

LH-E27

- KERAMICKÁ OBJÍMKA
- keramické tělo
- výborná tepelná odolnost

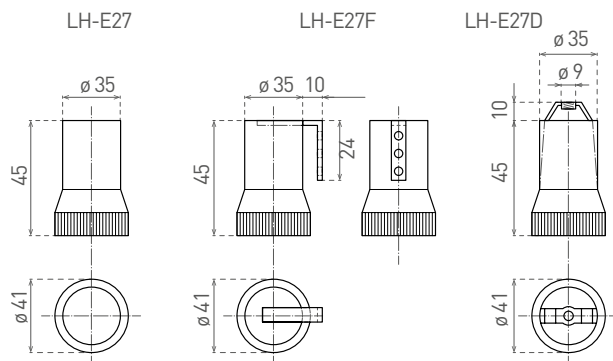

LH-E27	GX0S046	8592660103327	55	1/10/200
LH-E27F	GX0S047	8592660103334	70	1/10/200
LH-E27D	GX0S048	8592660103341	65	1/10/200

LH-GX5,3

- KERAMICKÁ OBJÍMKA
- keramické tělo
- výborná tepelná odolnost
- pocínované měděné vodiče
- izolace ze silikonu

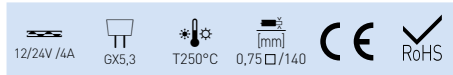
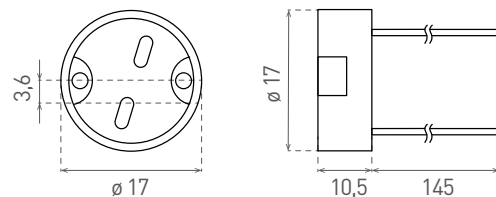

LH-GX5,3	GX0S045	8592660103310	8	10/500